

P&E Microcomputer Systems, Inc.  
 98 Galen Street Floor 2  
 Watertown  
 MA 02472  
 USA

DEMO9S08MP16 Schematic -- Main Page

Size A	FCSM No.	DWG No.	Rev B
Scale	Sheet 1 of 12		

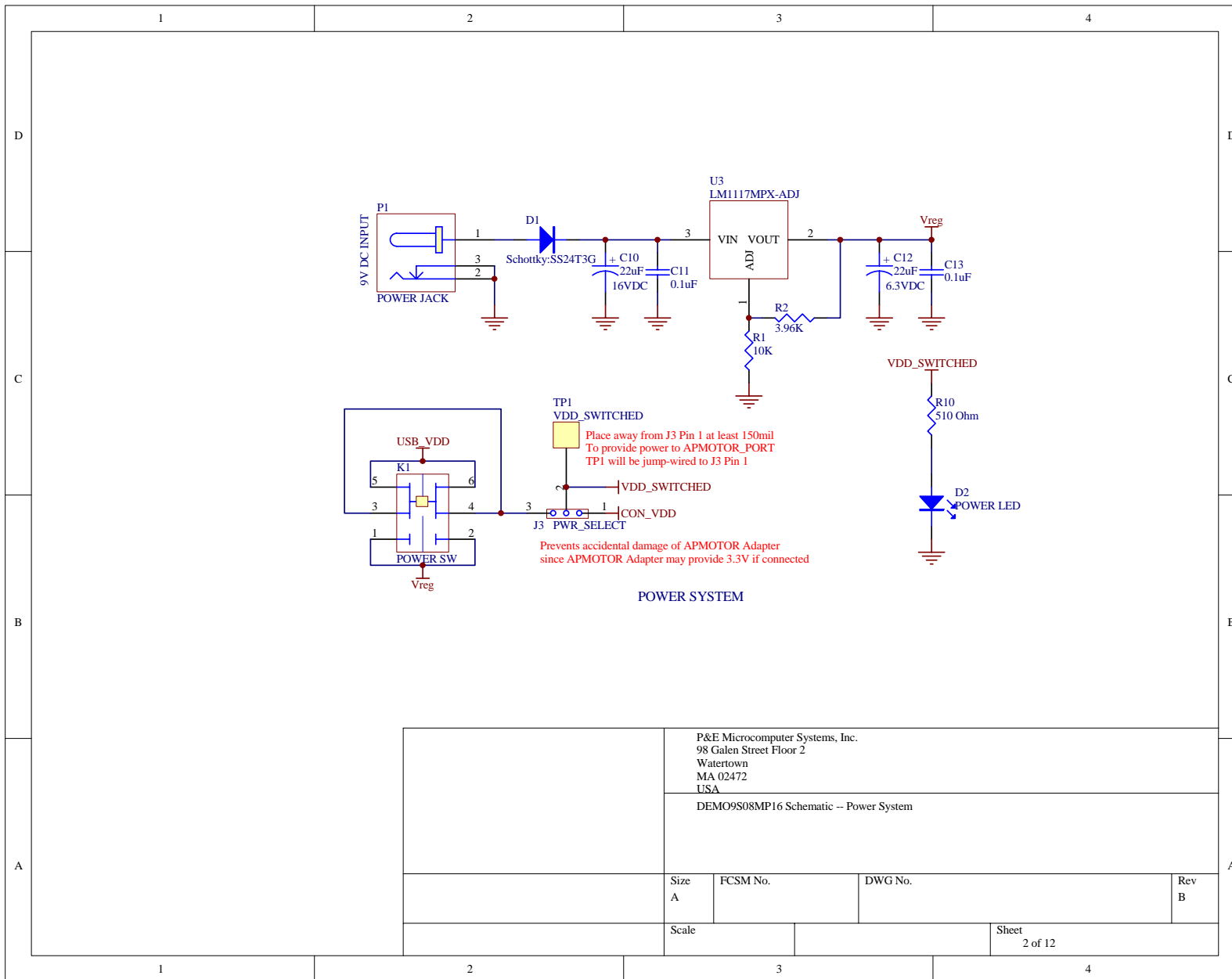

P&E Microcomputer Systems, Inc.  
 98 Galen Street Floor 2  
 Watertown  
 MA 02472  
 USA

DEMO9S08MP16 Schematic -- Power System

Size A	FCSM No.	DWG No.	Rev B
-----------	----------	---------	----------

Scale	Sheet 2 of 12
-------	------------------

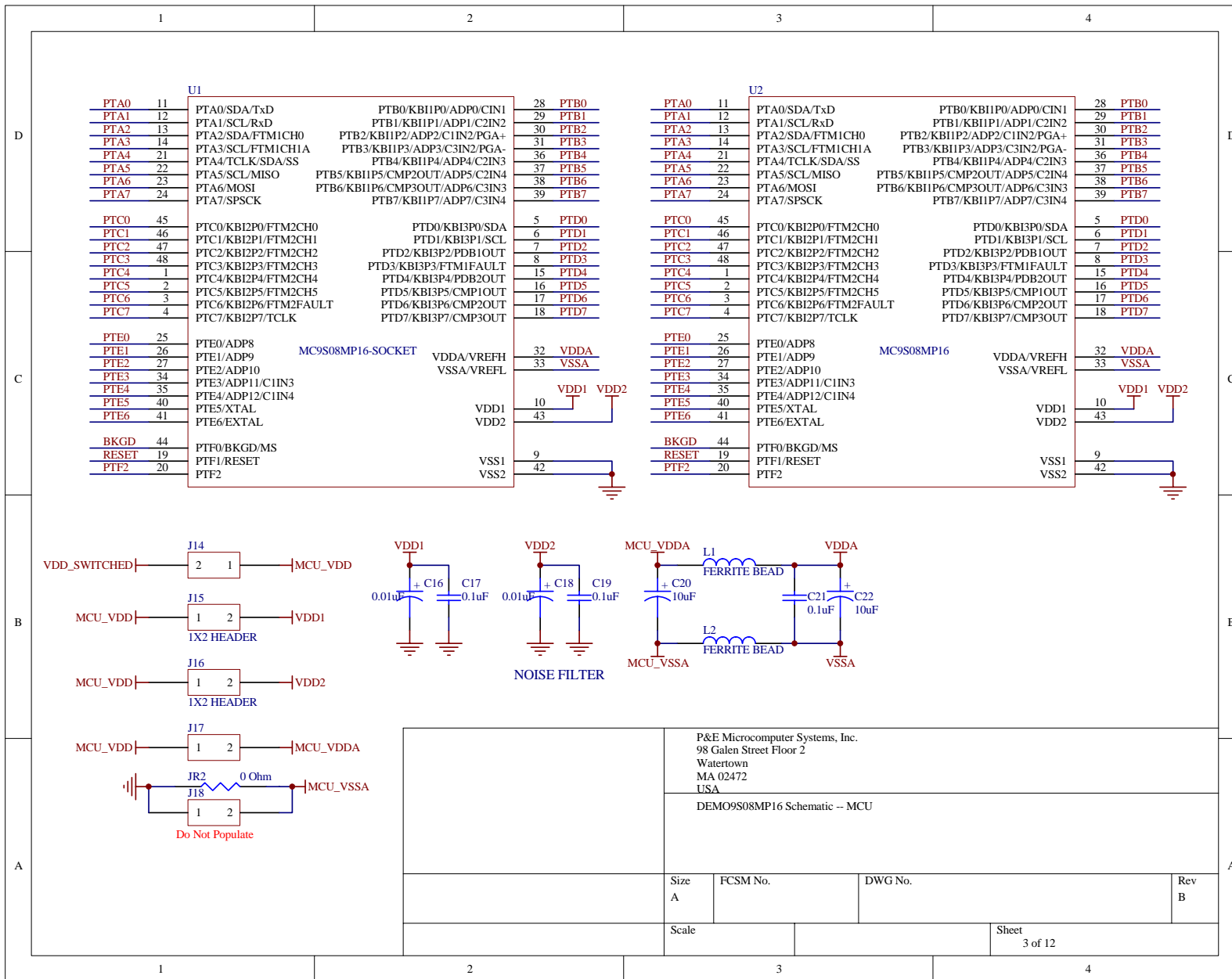

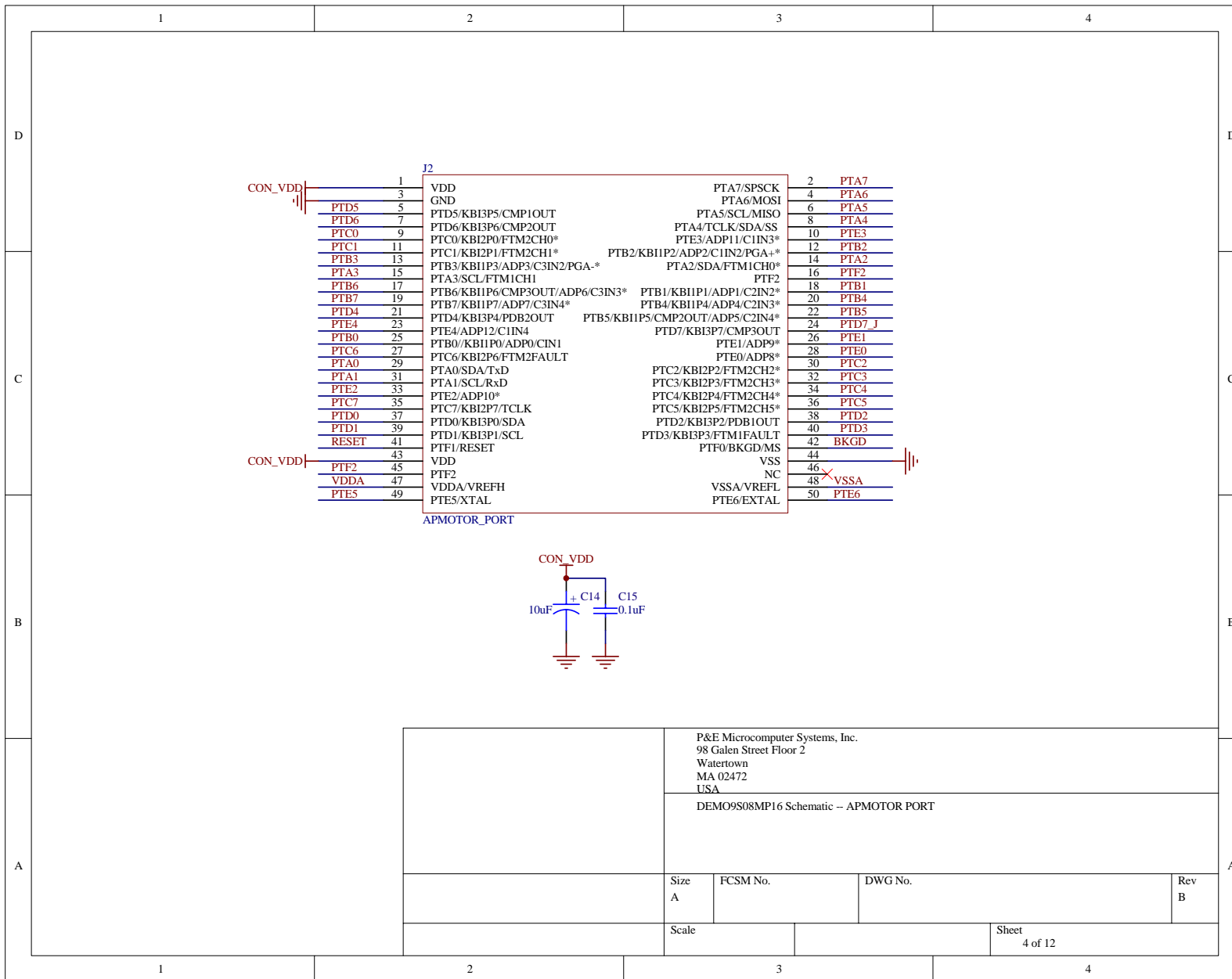

P&E Microcomputer Systems, Inc.  
 98 Galen Street Floor 2  
 Watertown  
 MA 02472  
 USA

DEMO9S08MP16 Schematic -- APMOTOR PORT

Size A	FCSM No.	DWG No.	Rev B
-----------	----------	---------	----------

Scale	Sheet 4 of 12
-------	------------------

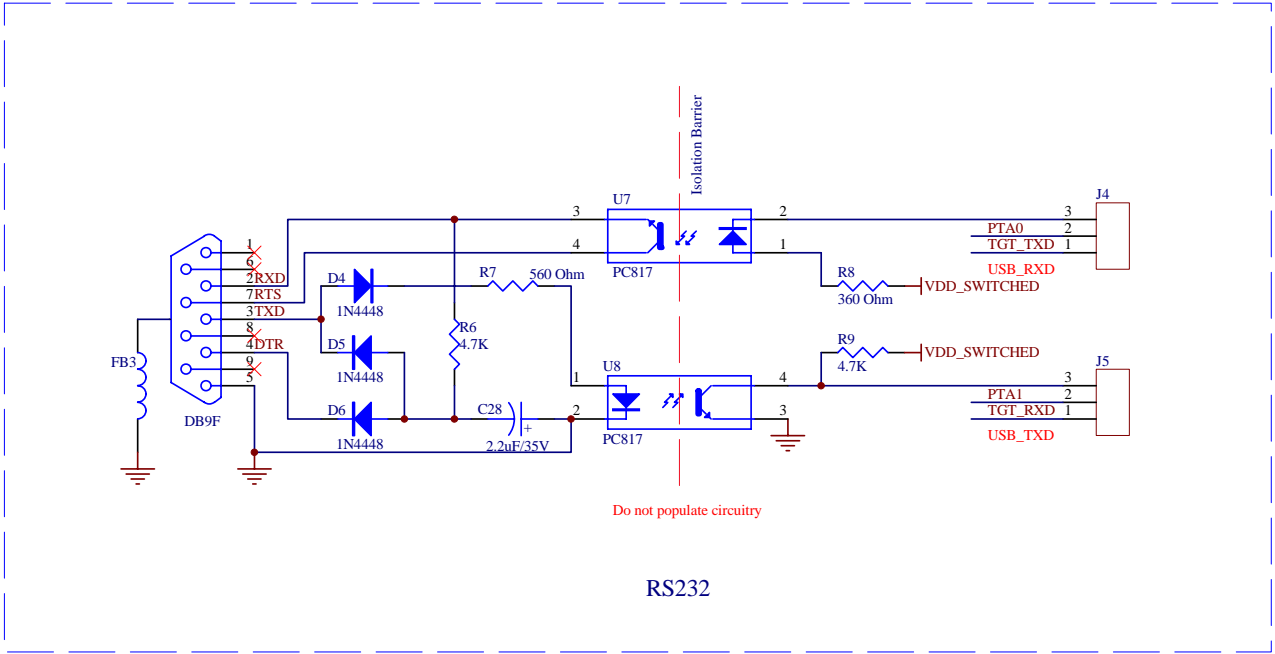

RS232

P&E Microcomputer Systems, Inc.  
 98 Galen Street Floor 2  
 Watertown  
 MA 02472  
 USA

DEMO9S08MP16 Schematic -- RS232

Size A	FCSM No.	DWG No.	Rev B
-----------	----------	---------	----------

Scale	Sheet 5 of 12
-------	------------------

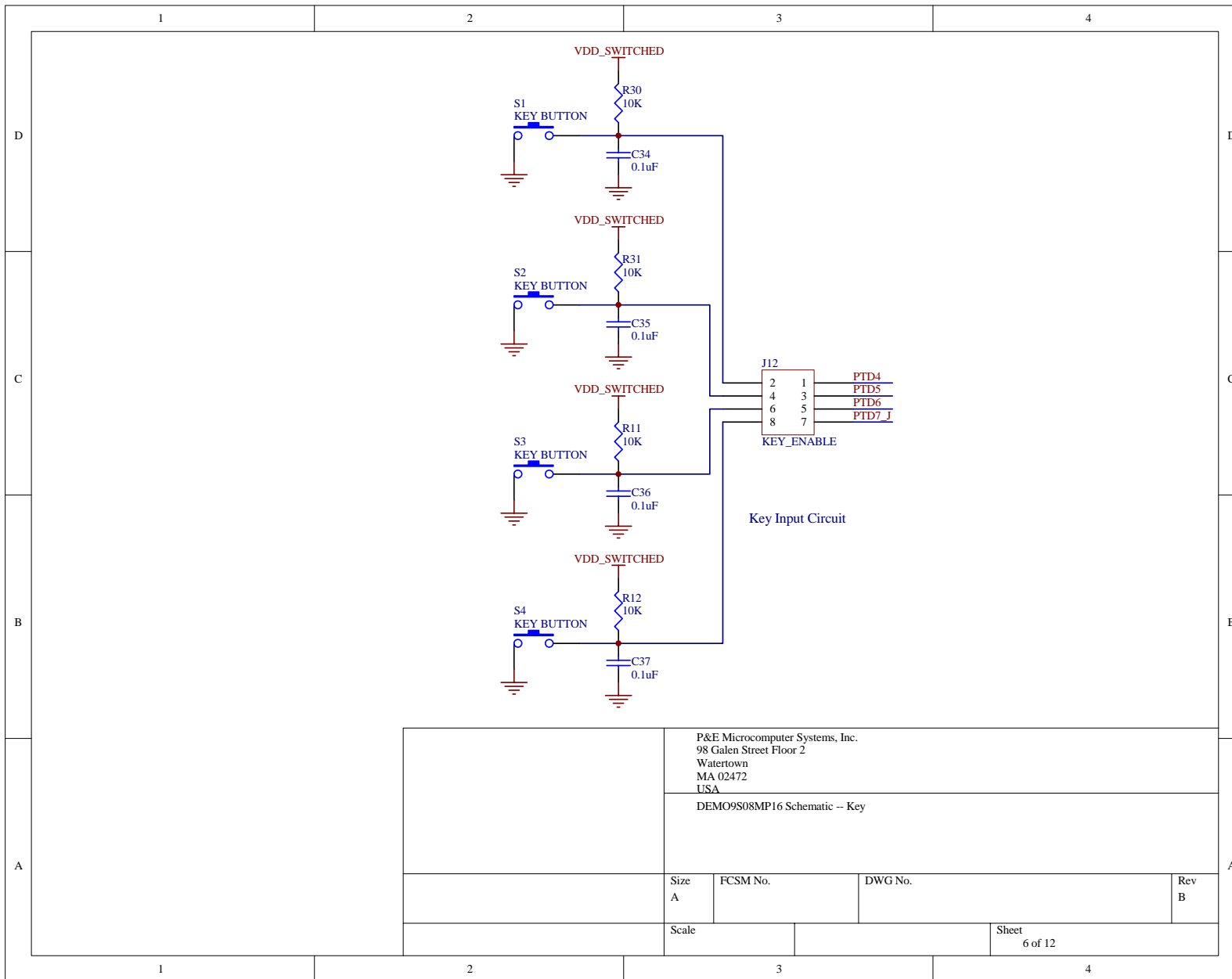

P&E Microcomputer Systems, Inc.  
 98 Galen Street Floor 2  
 Watertown  
 MA 02472  
 USA

DEMO9S08MP16 Schematic -- Key

Size A	FCSM No.	DWG No.	Rev B
Scale	Sheet 6 of 12		

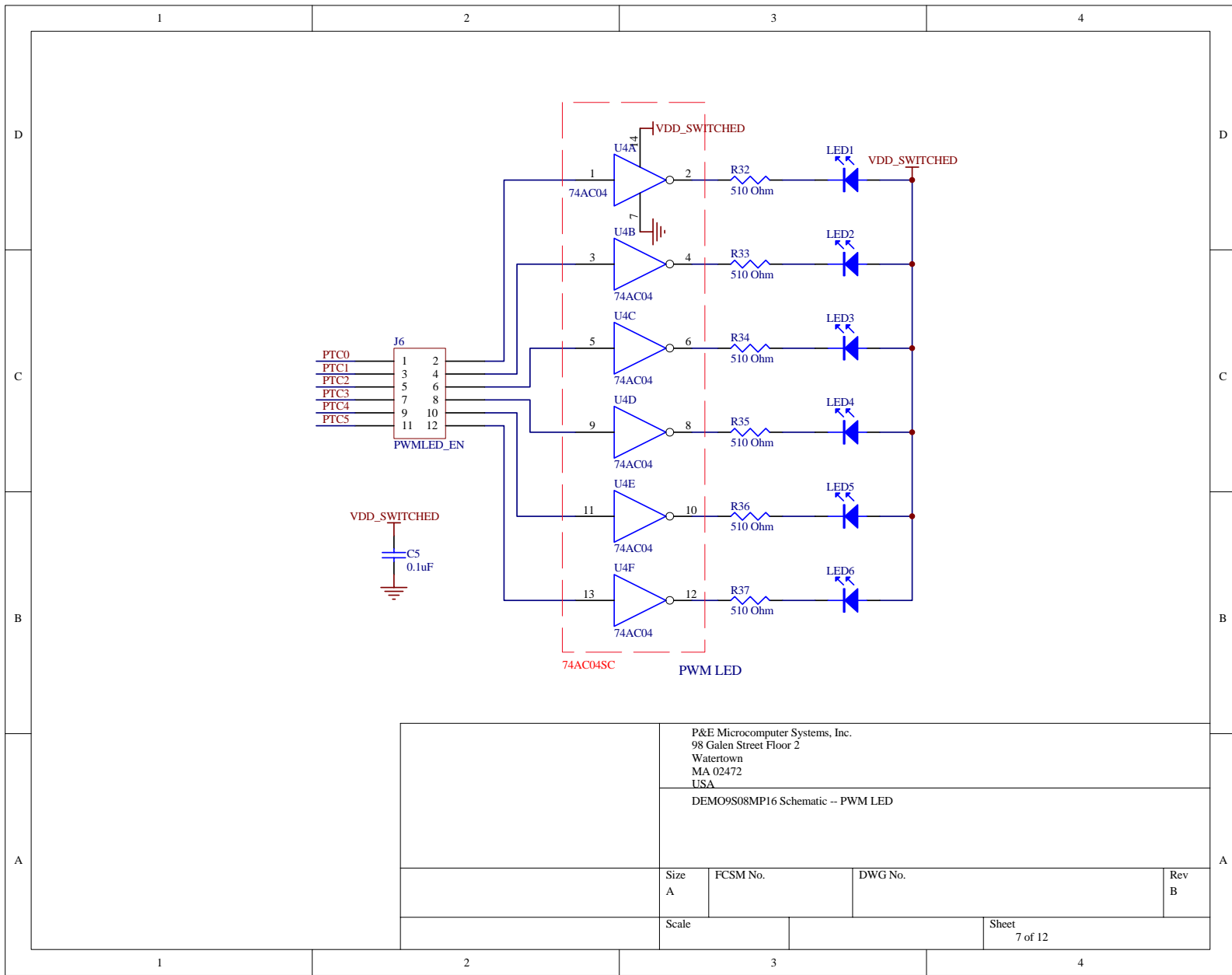

P&E Microcomputer Systems, Inc.  
 98 Galen Street Floor 2  
 Watertown  
 MA 02472  
 USA

DEMO9S08MP16 Schematic -- PWM LED

Size A	FCSM No.	DWG No.	Rev B
-----------	----------	---------	----------

Scale	Sheet 7 of 12
-------	------------------

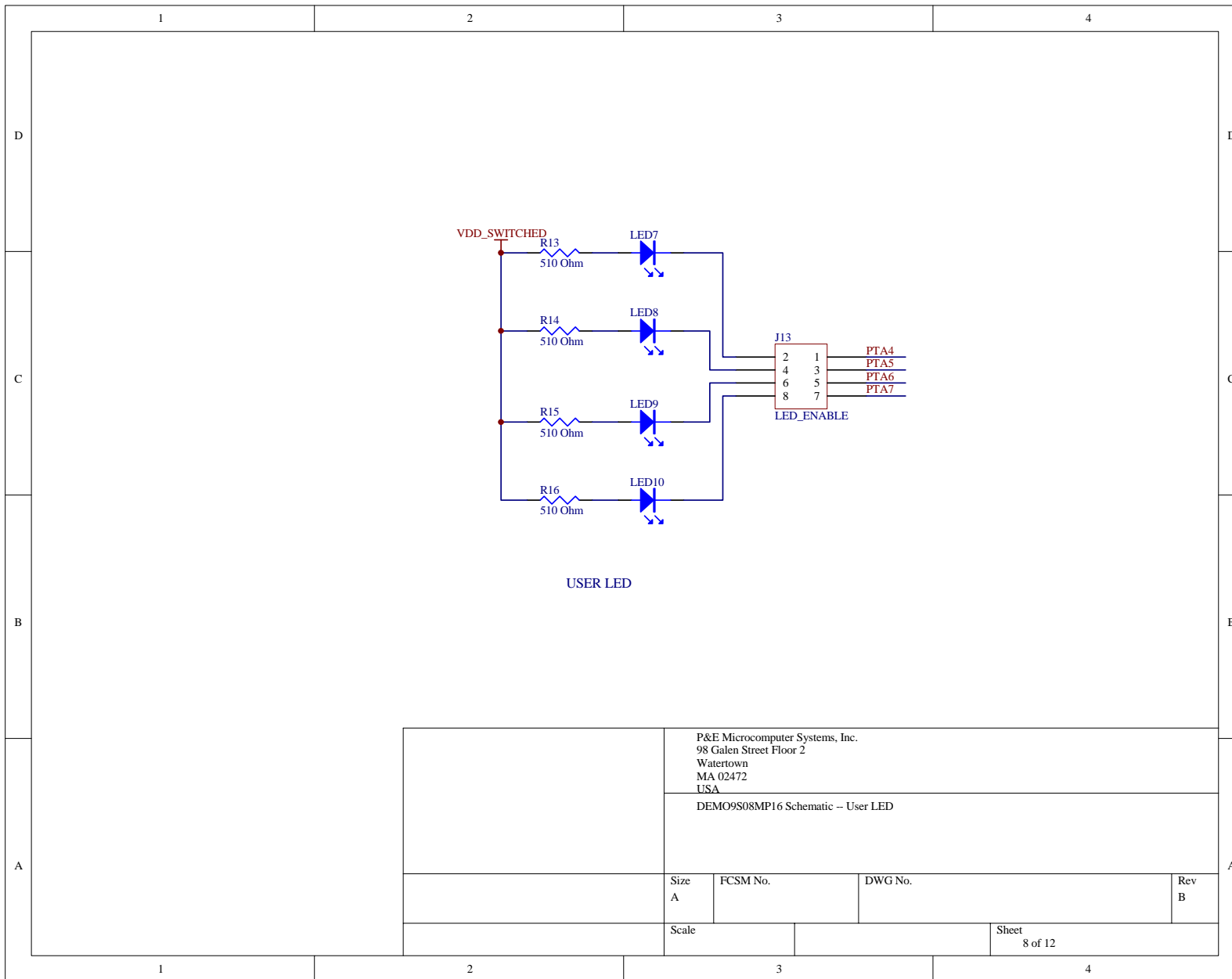

P&E Microcomputer Systems, Inc.  
 98 Galen Street Floor 2  
 Watertown  
 MA 02472  
 USA

DEMO9S08MP16 Schematic -- User LED

Size A	FCSM No.	DWG No.	Rev B
Scale	Sheet 8 of 12		



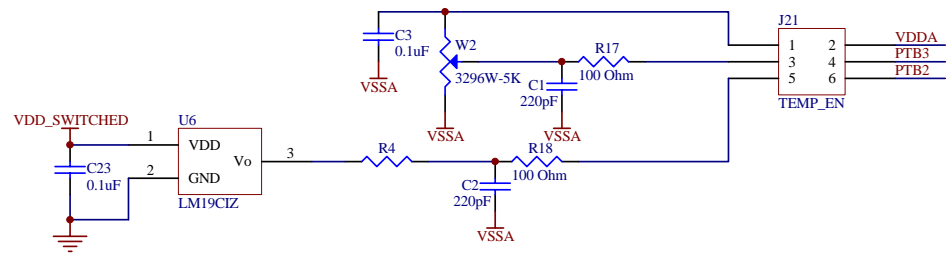

$$T = -1481.96 + \sqrt{2.1962 \cdot 10^6 + (1.8639 - V_o) / (3.88 \cdot 10^{-6})}$$

Temperature Sensor Circuit

P&E Microcomputer Systems, Inc.  
 98 Galen Street Floor 2  
 Watertown  
 MA 02472  
 USA

DEMO9S08MP16 Schematic -- Temperature Sensor

Size A	FCSM No.	DWG No.	Rev B
Scale	Sheet 9 of 12		

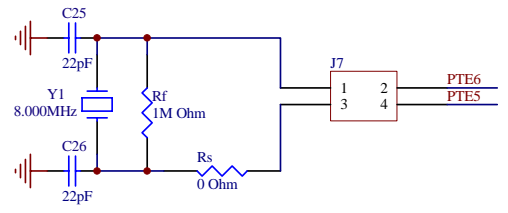

EXTERNAL CRYSTAL  
Do not populate

P&E Microcomputer Systems, Inc.  
98 Galen Street Floor 2  
Watertown  
MA 02472  
USA

DEMO9S08MP16 Schematic -- External Crystal

Size A	FCSM No.	DWG No.	Rev B
Scale	Sheet 10 of 12		

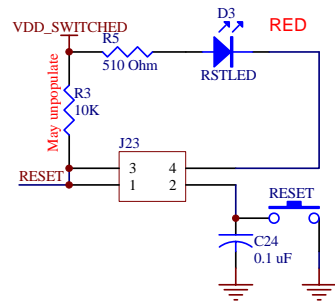

RESET CIRCUIT

P&E Microcomputer Systems, Inc.  
 98 Galen Street Floor 2  
 Watertown  
 MA 02472  
 USA

DEMO9S08MP16 Schematic -- Reset

Size A	FCSM No.	DWG No.	Rev B
Scale	Sheet 11 of 12		

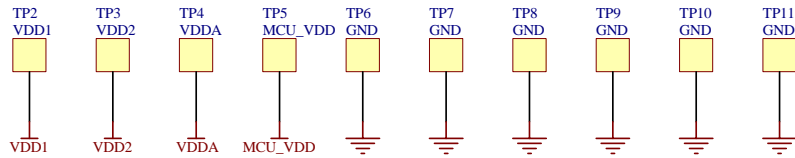
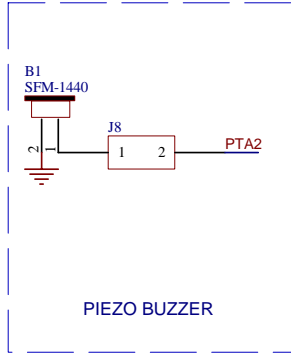
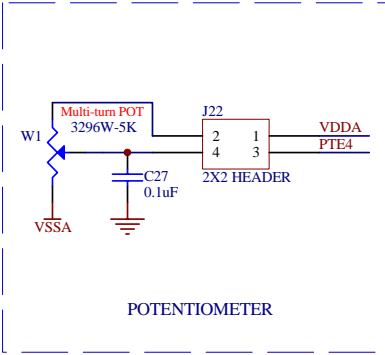
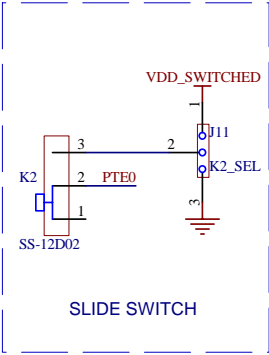
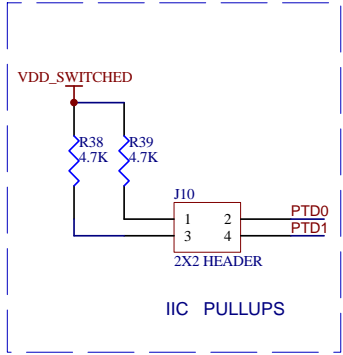

TEST POINTS

P&E Microcomputer Systems, Inc.  
 98 Galen Street Floor 2  
 Watertown  
 MA 02472  
 USA

DEMO9S08MP16 Schematic -- Misc

Size A	FCSM No.	DWG No.	Rev B
-----------	----------	---------	----------

Scale	Sheet 12 of 12
-------	-------------------

